

Vanity Unit Assembly Instructions

Low Level Furniture Packs G & H

End Panel / Cabinet
drilling pattern

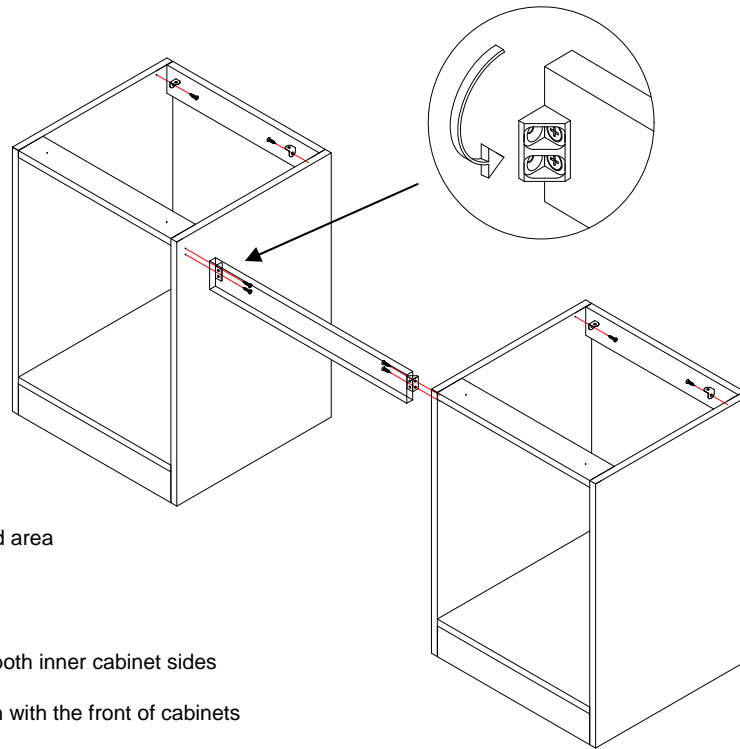
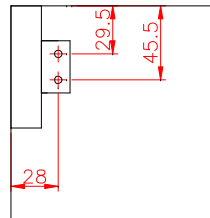

1

Position units in designated area
prior to assembly

Using 5/8 x 8 Screws:

- Attach L-Brackets to both inner cabinet sides
- Fix Knee Battern flush with the front of cabinets

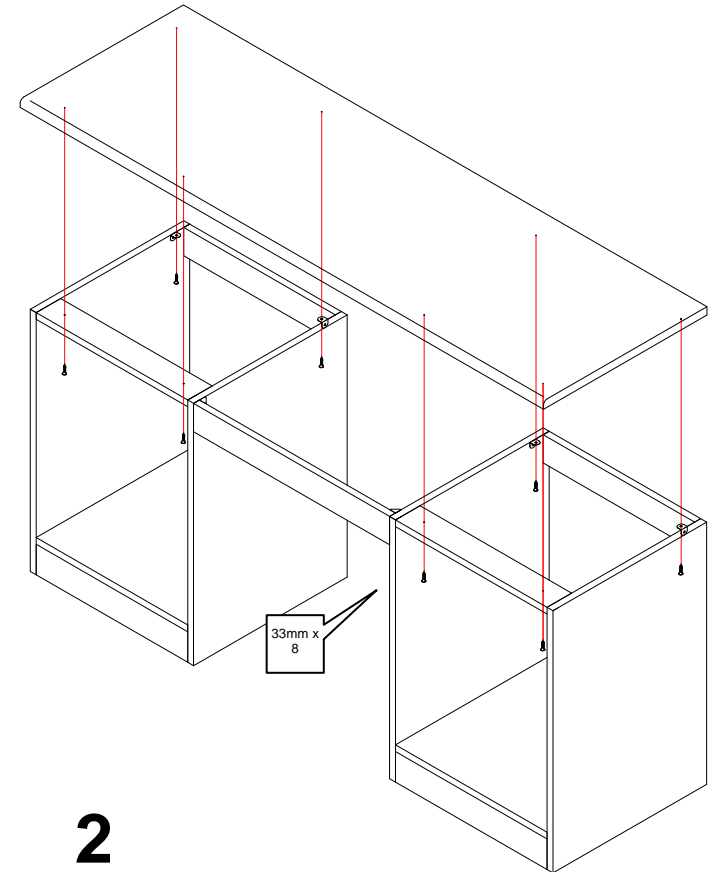

2

Position Worktop flush to the rear
of units with a 1mm over hang at either
end

Using 33mm x 8 Screws:

- Screw up through Cabinet Front Rail & into Worktop

Using 5/8 x 8 Screws:

- Complete the unit by fixing worktop through all
remaining L-Brackets

Fixings Pack Components

Please Note: We recommend all fixing points are pilot drilled prior to assembly



4 x L - Bracket



12 x 5/8 x 8 c/s
Screw



4 x 33mm x 8 c/s
Screw

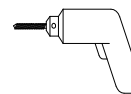
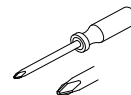

Symphony®